

INSTITUTE OF FOOD AND RESOURCE ECONOMICS
UNIVERSITY OF COPENHAGEN



MSAP Working Paper Series

No. 06/2010

Weighted Overlap Dominance - A Procedure for Interactive Selection on Multidimensional Interval Data

Jens Leth Hougaard

Institute of Food and Resource Economics

University of Copenhagen

Kurt Nielsen

Institute of Food and Resource Economics

University of Copenhagen



Weighted Overlap Dominance - A Procedure for Interactive Selection on Multidimensional Interval Data

Jens Leth Hougaard and Kurt Nielsen*

January 21, 2011

Abstract

We present an outranking procedure that supports selection of alternatives represented by multiple attributes with interval valued data. The procedure is interactive in the sense that the decision maker direct the search for preferred alternatives by providing weights of the different attributes as well as parameters related to risk attitude and weighted dominance. The outranking relation builds on pairwise comparisons between optimistic and pessimistic weighted values as well as weighted dominance relations supported by volume based measures. The suggested procedure is referred to as the Weighted Overlap Dominance procedure (WOD).

Keywords

Interactive decision making, interval data, outranking procedures, multi criteria decision making.

1 Introduction

In the present paper we suggest to use an interactive outranking procedure designed for situations where a decision maker wishes to rank a set of alternatives, each described by multiple attributes with interval data. The suggested procedure will be dubbed the Weighted Overlap Dominance procedure (WOD).

By now there is a substantial literature on multicriteria outranking methods, see e.g., Chen and Hwang (1992). Best known are: ELECTRE (Roy (1972)), VIKOR (Opricovic and Tzeng

*Institute of Food and Resource Economics, University of Copenhagen, Rolighedsvej 25, 1958 Frederiksberg C., Denmark. E-mails: jlh@foi.dk and kun@life.ku.dk

(2007), where Sayadi et al. (2009) extends to interval data), PROMETHEE (e.g. Brans and Vincke (1985). Teno and Mareschal (1998) extends to interval data) and TOPSIS (Chen and Hwang (1992)). Jahanshahloo et al. (2006) and Jahanshahloo et al. (2009) extends to interval data).

Whilst these methods can be extended to incorporate interval data, the suggested WOD procedure is directly constructed for pairwise comparisons of alternatives represented by multidimensional interval data and this is an important difference between WOD and the approaches of ELECTRE, VIKOR, PROMETHEE and TOPSIS - a difference which will be further discussed in Section 2 below. Loosely speaking, the outranking in WOD is based on weighted overlap between the alternatives represented as data cubes. The decision maker specifies criteria weights as well as a number of decision parameters relating to overlap size as measured by volume ratios.

The WOD method is intended as an integrated part of a decision support system. We imagine a situation with an analyst providing the initial set of alternatives and a decision maker providing preference information concerning the size of the various choice parameters of WOD. The analyst then provides the resulting ranking and the decision maker further consider revising his choice of parameters and so forth in an ongoing iterative process until an acceptable result is obtained. Consequently, the decision support system may be divided into: 1) a pre-analysis and processing of data by the analyst and 2) communication and interaction between the decision maker and the analyst concerning choice parameters as well as intermediate results.

As input to the system, the analyst provides one or more sets of interval data for each criteria and alternative. In cases where data can be seen as realizations of some underlying random variable, the interval representation can be constructed as a simplification of the true underlying data distribution. In this case multiple sets of interval data will collectively provide an improved approximation. The first set of interval data may, for example, represent the boundaries containing 95 % of all likely outcomes, the second set 85 % etc. Clearly, the nature of the decision problem is crucial for the number of relevant sets.

With interval data in place for each alternative, the WOD method provides a sorted list of alternatives as a function of the user's stated choice parameters. To ease the communication we suggest two different user interfaces: A) one that presents a single sorted list of alternatives (in equivalence classes) given the choice of interval data (e.g. the boundary including 95 % of all likely outcomes) and B) one that presents multiple sorted lists of alternatives, one for each set of interval data. Option A) provides room for presenting actual numbers of the different criteria for each alternative and option B) provides an overview of how the ranking changes according to the other sets of interval data (data uncertainty). In either case the user can state his preferences in terms of weights, risk attitude and weighted dominance. The system produces new sorted lists of alternatives as these preferences change.

The potential field of applications is to some extent similar to that of the related methods ELECTRE, PROMETHEE, TOPSIS and VIKOR. For instance, in connection with variant of the TOPSIS method, Sun (2010) lists a number of actual applications ranging from "ranking hotels based on evaluation information" to "selecting orders in make-to-order basis when orders

exceed production capacity”. Particularly relevant areas of application for the suggested WOD procedure are characterized by a significant data uncertain making interval data representation appropriate.

The outline of the paper is as follows. Section 2 motivates the suggested WOD method and relate WOD to other well-known outranking methods. Section 3 defines the WOD procedure in detail. Section 4 provides an illustrative application comparing WOD to an interval version of TOPSIS. Section 5 suggests how to imbed WOD into an interactive decision support framework and 6 concludes with a few remarks on potential real world applications.

2 WOD: Motivation and Relation to Other Methods

The WOD procedure concerns pairwise outranking of alternatives. As such, it primarily relates to four other well-known approaches: ELECTRE, PROMETHEE, TOPSIS and VIKOR. These methods have been compared in several papers, e.g. Opricovic and Tzeng (2007, 2004). In the following we shall briefly discuss differences and similarities between these methods and WOD.

In short, the idea of the ELECTRE method (Roy (1972), Roy (1996)) is to define a set of criteria supporting and rejecting respectively a given outranking relation. The supporting criteria are then associated with an aggregate weight whereas criteria for which the outranking relation is rejected are associated with individual scores. One alternative is now said to outrank another if the total weight supporting the outranking relation is above a certain threshold and no criterion is rejected with a score above a certain level. Concerning the details of the method, it should be noted that four different versions of the approach exists.

The PROMETHEE method, see e.g. Brans and Vincke (1985) introduces ‘net preferences flows’ as aggregating functions. In short, user determined preference functions and weights are associated to each criterion and outranking degrees are determined for each pairwise comparison of alternatives leading to leaving, entering and net ‘flows’ (average outranking degrees) for each alternative. Teno and Mareschal (1998) provides one way of extending this approach to include interval data.

In the TOPSIS method, see e.g. Chen and Hwang (1992), user determined weights are used to score the alternatives and a ranking is based on the relative (normed) closeness to an ideal solution (the hypothetical alternative having maximal score in each criterion) and (normed) distance to an anti-ideal solution (the hypothetical alternative having minimal score in each criterion). Jahanshahloo et al. (2006) and Jahanshahloo et al. (2009) extends this approach to interval data.

The VIKOR method, see e.g. Opricovic (1998), is also based on distances to an ideal and anti-ideal solution respectively. These distances are weighted and normed and a compromise solution is determined. See Opricovic and Tzeng (2004) for a detailed comparison of VIKOR and TOPSIS. Sayadi et al. (2009) provide an extension to interval data.

As mentioned in the introduction, the WOD method is constructed to handle pairwise comparisons of alternatives represented by interval data. The fact that it is directly constructed for interval data is a first important aspect distinguishing WOD from the other methods. For example, in case of substantial data uncertainty we find it crucial that the outranking relation between any pair of alternatives is independent of the presence of other alternatives in the choice set. If this is not the case then the uncertainty of (irrelevant) alternatives may influence the outranking relation between the pair of alternatives in question. Such independence of "irrelevant" alternatives is satisfied by WOD (by construction) but *not* by methods like TOPSIS and VIKOR even these can be extended to handle interval data. Based on distances to an ideal and anti-ideal defined over the entire choice set, the resulting ranking of these methods depend on data from all alternatives. We find this a significant drawback of the TOPSIS and VIKOR methods when handling alternatives that are characterized by highly uncertain data.

It is not obvious how methods like ELECTRE and PROMETEE can be extended to handle interval data. For PROMETEE one idea is found in T eno and Mareschal (1998). Compared to the suggested WOD procedure the decision maker has to be much more specific in defining when alternatives are preferred to other alternatives since PROMETEE builds on (user defined) criteria specific preference functions for each pair of alternatives. Setting up such preference functions is quite demanding in terms of information from the decision maker and introducing uncertainty in the form of interval data does not add to a simplification. Moreover, depending on how the extension to interval data is done, it is far from clear how the uncertainty of one alternative will influence the outranking relation between two other alternatives.

As in the vast majority of multicriteria methods the suggested WOD procedure will rely on quantitative criteria weights in order to reflect the relative importance of each criterion. Given such weights each alternative, represented by its data cube (multidimensional interval data), possesses a maximum and a minimum weighted value. Compared to the alternative that obtains the highest maximum weighted value all dominated alternatives are disregarded. Then, based on weighted values, the 'overlap' between pairs of remaining alternatives are considered and an outranking relation is defined according to how likely (value) dominance occur as well as according to the decision makers risk attitude. Whether value dominance occurs or not is a judgement based on volume measures. Consider Figure 1 and 2 below, representing two types of situations of pairwise comparisons (in a two-dimensional model).

In case of Figure 1 it is clear that the respective maximum and minimum weighted value of alternative A is larger than that of alternative B. Hence, from the outset it seems reasonable to conclude that B can never outrank A from a value maximizing perspective. However, if the size of the marked area for alternative B is sufficiently large, the decision maker may feel that A and B are equally desirable. Using WOD, B can never outrank A, but with suitable choice of parameters, A and B may end up in the same equivalence class. Note that (interval extensions of) methods like TOPSIS may actually result in situations where B strictly outranks A.

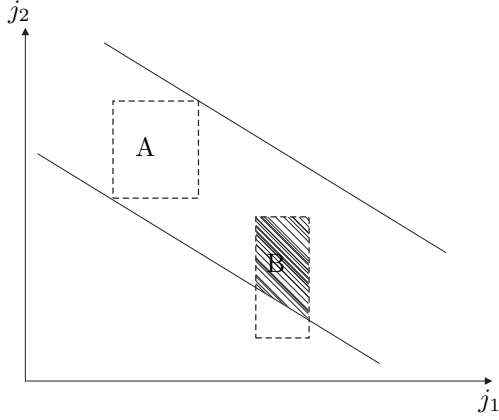

Figure 1: *Pairwise comparison type 1*

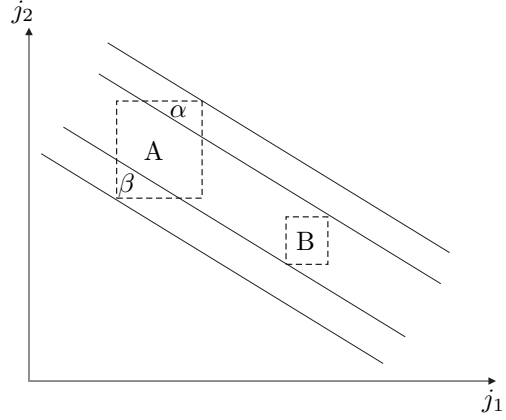

Figure 2: *Pairwise comparison type 2*

The case of Figure 2 is more ambiguous. Here, there is no evident dominance relation since even though the maximum weighted value of A is larger than that of B, the minimum weighted value of B is larger than that of A. In this case it seems reasonable to consider the relative size of the areas α and β , where α is a proxy for the part of A being better than B while β is a proxy for the part of B being better than A. In fact, it is tempting to consider the ratio between these volumes as measuring the risk attitude of the decision maker, which is done in WOD. Using (interval extensions of) methods like TOPSIS may result in A outranking B, while a risk averse decision maker might well find B more desirable than A as would indeed be the result of WOD. At least in the interval versions of TOPSIS presented in Jahanshahloo et al. (2006) and Jahanshahloo et al. (2009) there is no parameter that represents the risk attitude of the decision maker - another drawback in case of uncertain alternatives.

3 The WOD Procedure

Consider a set $N = \{1, \dots, n\}$ of potential alternatives, each characterized by a set $M = \{1, \dots, m\}$ of different criteria. Let data be interval valued $[x_{ij}^L, x_{ij}^U]$ and consider the normalized score of alternative $i \in N$ with respect to criteria $j \in M$ given by $y_{ij} = [y_{ij}^L, y_{ij}^U]$, where

$$y_{ij}^L = \frac{x_{ij}^L}{\sqrt{(x_{ij}^L)^2 + (x_{ij}^U)^2}}$$

and

$$y_{ij}^U = \frac{x_{ij}^U}{\sqrt{(x_{ij}^L)^2 + (x_{ij}^U)^2}}.$$

For each alternative $i \in N$, (normalized) data hence consists of the m -dimensional cube $c_i = [y_{ij}^L, y_{ij}^U]^m$.

We say that one cube c_i *dominates* another cube c_z if $y_i^L = (y_{i1}^L, \dots, y_{im}^L) > (y_{z1}^U, \dots, y_{zm}^U) = y_z^U$, i.e. if the minimal values of c_i all are larger than the maximal values of c_z .

Let $w \in \mathbf{R}_+^m$ be a vector of criteria weights (as expressed by the decision maker) and consider an alternative i_o in the set determined by solutions to,

$$i_o = \arg \max_{i \in N} w \cdot y_i^U,$$

i.e. an alternative for which the maximal weighted value is obtained.

Relative to the alternative i_o we now define an index $I_{i_o}(z)$ measuring the weighted overlap between i_o and all other alternatives $z \in N$ as follows:

$$I_{i_o}(z) = \frac{V(c_z|i_o)}{V(c_z)} \in [0, 1], \quad (1)$$

where

$$c_z|i_o = \{x \in [y_{zj}^L, y_{zj}^U]^m \mid w \cdot x \geq w \cdot y_{i_o}^L\}$$

and $V(\cdot)$ is the volume operator with $V(\emptyset) = 0$. Note that $c_z|i_o$ is empty if c_z is dominated by i_o implying that $I_{i_o}(z) = V(\emptyset)/V(c_z) = 0$ in this case. See Figure 3 for an illustration.

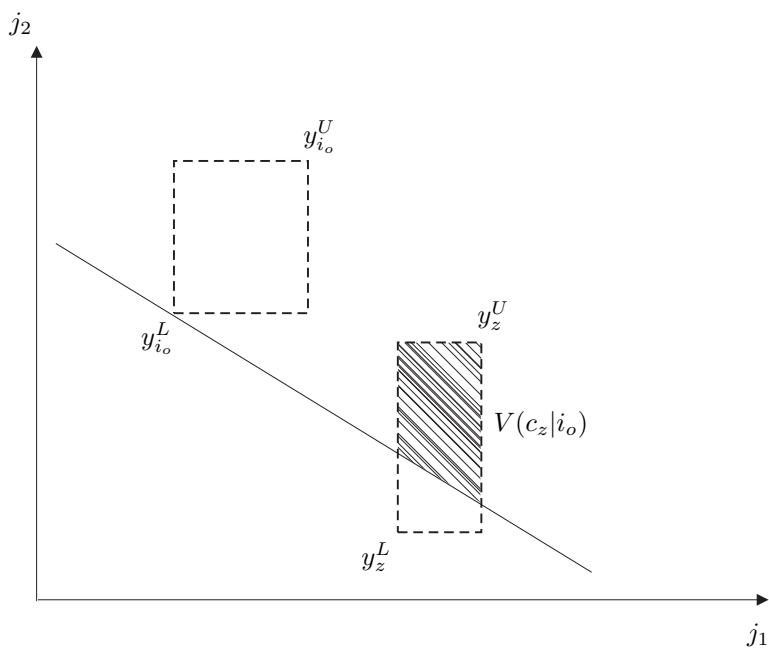

Figure 3: *Initial exclusion of alternatives.*

Let $\mathcal{Z} = \{z \in N \mid I_{i_o}(z) \geq \alpha, \alpha \in [0, 1]\} \subseteq N$ be the set of alternatives with α percentage weighted overlap relative to i_o (note that \mathcal{Z} contains i_o itself since $I_{i_o}(i_o) = 1$ and hence is

non-empty). The parameter α can be considered as exogenously chosen by the decision maker in order to reduce the initial set of relevant alternatives (or by the analyst for the same purpose). Note that if $\mathcal{Z} = \{i_o\}$ then i_o will be the natural selection.

Hence, assume that $\mathcal{Z} \neq \{i_o\}$ and consider all

$$\frac{|\mathcal{Z}|!}{2!(|\mathcal{Z}| - 2)!}$$

pairs $z, z' \in \mathcal{Z}$.

For each pair $z, z' \in \mathcal{Z}$ assume that $w \cdot y_z^U \geq w \cdot y_{z'}^U$ (otherwise relabel). Define the sets,

$$\hat{Z} = \{x \in [y_{z_j}^L, y_{z_j}^U]^m \mid w \cdot x > w \cdot y_{z'}^U\}, \quad (2)$$

$$\check{Z} = \{x \in [y_{z_j}^L, y_{z_j}^U]^m \mid w \cdot x < w \cdot y_{z'}^L\}, \quad (3)$$

and

$$\tilde{Z}' = \{x \in [y_{z'_j}^L, y_{z'_j}^U]^m \mid w \cdot x > w \cdot y_z^L\}. \quad (4)$$

See Figure 4 and 5 below for an illustration of the three sets \hat{Z} , \check{Z} and \tilde{Z}' (as volumes). Note that \hat{Z} is empty if and only if $w \cdot y_z^U = w \cdot y_{z'}^U$, \check{Z} is empty if and only if $w \cdot y_{z'}^L \leq w \cdot y_z^L$ and \tilde{Z}' is empty if and only if $w \cdot y_{z'}^U \leq w \cdot y_z^L$.

We now define the outranking relation \succ on \mathcal{Z} as follows:

If $\tilde{Z}' = \emptyset$ then z outranks z' (written $z \succ z'$).

If $\check{Z} = \emptyset$ then

$$z \succ z' \Leftrightarrow P(z > z') > \beta,$$

where

$$P(z > z') = \frac{V(\hat{Z})}{V(c_z)} + \frac{V(c_z \setminus \hat{Z})}{V(c_z)} \frac{V(c_{z'} \setminus \tilde{Z}')}{V(c_{z'})}$$

and $\beta \in [0, 1]$ is a parameter chosen by the decision maker. Otherwise the two alternatives are considered equivalent, i.e., $z \sim z'$.

If $\check{Z} \neq \emptyset$ then

$$z \succ z' \Leftrightarrow \frac{V(\hat{Z})}{V(\check{Z})} > \gamma,$$

$$z \sim z' \Leftrightarrow \frac{V(\hat{Z})}{V(\check{Z})} = \gamma,$$

and

$$z' \succ z \Leftrightarrow \frac{V(\hat{Z})}{V(\check{Z})} < \gamma,$$

where $\gamma \in \mathbf{R}_+$ is a parameter chosen by the decision maker. The different components in the indexes are illustrated in Figure 4 and 5 below.

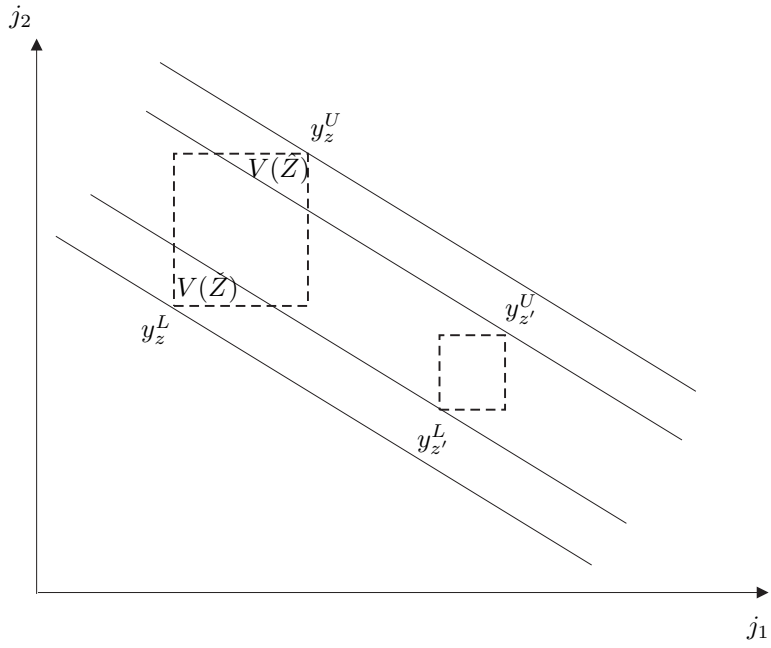

Figure 4: *Outranking in case of two-sided overlap: $\tilde{Z} \neq \emptyset$.*

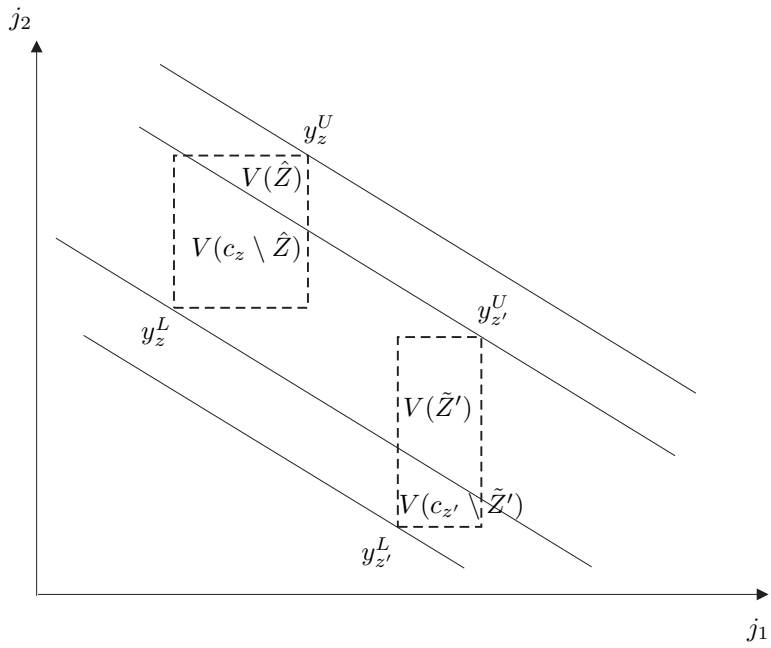

Figure 5: *Outranking in case of one-sided overlap: $\tilde{Z} = \emptyset$.*

The first part is straightforward since in case $\tilde{Z}' = \emptyset$ we have that lowest value of z is greater than the highest value of z' and hence z outranks z' given the chosen weights w . The second part relates to the case where the value intervals of z and z' overlap. The scoring $P(z > z')$ can be interpreted as how likely it is that z is having a higher value than z' . If the scoring is high enough we say that z outranks z' , otherwise the two alternatives are considered equivalent. Finally, the last part deals with the case where the value interval of z' is a subset of the value interval of z and choice between them therefore becomes a matter of risk attitude. The ratio $V(\hat{Z})/V(\check{Z})$ reflects the probability of z having a higher value than the maximal value of z' to the probability of z having a lower value than the minimal value of z' . Thus, if $\gamma = 1$ the decision maker can be seen as risk neutral, if $\gamma > 1$ as risk averse, and if $\gamma < 1$, as risk loving. If the ratio $V(\hat{Z})/V(\check{Z}) < \gamma$ we conclude (reversely) that z' outranks z .

As straightforward consequences of the definition of the WOD procedure we record that:

Proposition 1. *Given the decision makers choice of parameters w , β and γ , then for any pair of alternatives the WOD procedure results in either an outranking relation \succ or an equivalence relation \sim .*

and

Proposition 2. *Given the decision makers choice of parameters w , β and γ , the WOD procedure is affine invariant, i.e., it produces the same ranking if data is transformed by $x_i \rightarrow a_i x_i + b_i$ for $a_i, b_i \in \mathbf{R}_+$.*

Remark: For fixed criteria weights w the result follows from normalization of data. However, the result also holds for non-normalized data if w is allowed to be changed in accordance with the re-scaling of data, i.e., if $w_i \rightarrow w_i/a_i$.

We can further show:

Proposition 3. *Given the decision makers choice of parameters w , β and γ , the WOD outranking relation \succ on \mathcal{Z} is semi-transitive, i.e.*

$$z \succ z', z' \succ z'' \not\Rightarrow z'' \succ z.$$

Proof: Fix an alternative z and consider another alternative z' , where $z \succ z'$.

If $\tilde{Z}' = \emptyset$ and $z' \succ z''$ for a third alternative z'' then clearly $z \succ z''$.

If $\tilde{Z} = \emptyset$ we have $P(z \succ z') > \beta$. Now, consider a third alternative z'' where $z' \succ z''$. If $\tilde{Z}'' = \emptyset$ it is clear that $z \succ z''$. If $\tilde{Z}' = \emptyset$ we have $P(z' \succ z'') > \beta$ implying that $w \cdot y_{z''}^U \leq w \cdot y_{z'}^U$

and $w \cdot y_{z''}^L \leq w \cdot y_{z'}^L$, which further implies that $P(z > z'') > \beta$. Thus, $z \succ z''$. If $\check{Z}' \neq \emptyset$ we have $V(\hat{Z}')/V(\check{Z}') > \gamma$. In case $w \cdot y_{z''}^L \geq w \cdot y_{z'}^L$ we clearly have that (the volume ratio on the relation between z and z'') $V(\hat{Z})/V(\check{Z}) \geq V(\hat{Z}')/V(\check{Z}') > \gamma$ and consequently $z \succ z''$. In case $w \cdot y_{z''}^L < w \cdot y_{z'}^L$ the particular choice of β can render z equivalent with z'' (but we can never have $z'' \succ z$).

If $\check{Z} \neq \emptyset$ we have $V(\hat{Z})/V(\check{Z}) > \gamma$. Now, consider a third alternative z'' where $z' \succ z''$. If $\check{Z}'' = \emptyset$ two cases may occur: i) If $w \cdot y_{z''}^U < w \cdot y_{z'}^L$ then obviously $z \succ z''$, ii) If $w \cdot y_{z''}^U \geq w \cdot y_{z'}^L$ then the particular choice of β may result in $z \sim z''$ (but we can never have $z'' \succ z$). If $\check{Z}' = \emptyset$ two cases may occur: i) If $w \cdot y_{z''}^L > w \cdot y_{z'}^L$ in which case the ratio $V(\hat{Z})/V(\check{Z})$ on the relation between z and z'' becomes less than the ratio $V(\hat{Z})/V(\check{Z})$ on the relation between z and z' , i.e., $V(\hat{Z})/V(\check{Z}) > \gamma$, and thereby we have $z \succ z''$, ii) If $w \cdot y_{z''}^L < w \cdot y_{z'}^L$ we are in a situation where $z \succ z''$ or $z \sim z''$ (but we can never have $z'' \succ z$). Finally, if $\check{Z}' \neq \emptyset$ then $V(\hat{Z}')/V(\check{Z}') > \gamma$ which implies that the ratio $V(\hat{Z})/V(\check{Z})$ on the relation between z and z'' is larger than γ too, which in turn implies that $z \succ z''$. Q.E.D.

We finally add the following straightforward observation:

Observation 4. *Looking at the cases $\check{Z} = \emptyset$ and $\check{Z} \neq \emptyset$ respectively,*

1. *An increase in β tends to increase the size of the equivalence classes.*
2. *An increase in γ lowers the likelihood that the alternative with maximal value outranks other alternatives.*

4 A Comparative Data Analysis

To provide an illustration of the suggested WOD procedure we will make a comparison with an interval version of TOPSIS. Thus, we apply the same data set as originally used in Jahanshahloo et al. (2006) to illustrate their interval extension of TOPSIS .

As mentioned earlier, the two procedures differ significantly. TOPSIS rank all alternatives by distances to the same constructed ideal and anti-ideal reference points. These reference points are not actually existing alternatives but infeasible goals made up by the extreme values across all alternatives. In contrast, WOD compare the alternatives two and two and then rank them accordingly.

In both procedures the ranking is influenced by user given criteria weights. However, the WOD procedure involves further decision variables to be settled by the user or the analyst.

The parameter α is introduced in order to limit the set of relevant alternatives. It is a form of pre-screening device: If $\alpha = 0$ all options are considered. With increasing α those alternatives which have only small value overlap are gradually excluded.

The parameters β and γ are introduced in order to provide a more nuanced ranking among the remaining alternatives.

The parameter β is used in case of one-sided overlap, as illustrated in Figure 3, where the worst and best outcome of alternative A both dominates those of alternative B . Here, β is used to define when the decision maker will find alternative B indifferent to A . If $\beta = 0$ there will be no equivalence classes and WOD provides a complete and strict ranking. With increasing β we get increasing equivalence classes.

Finally, the parameter γ is used in situations of two-sided overlap as illustrated in Figure 4, where the worst outcome of alternative B dominates the worst outcome in alternative A but where the best outcome of alternative A is dominates the best outcome of alternative B . γ reflects the user's risk attitude: $\gamma = 1$ can be viewed as risk neutrality while $\gamma > 1$ and $\gamma < 1$ can be viewed as risk aversion and risk attraction respectively.

Below, we shall illustrate how the three choice parameters in WOD provide a more flexible ranking procedure than that of TOPSIS. The applied data set covers 15 bank branches each represented by four financial ratios. Data is taken from Table 1 in Jahanshahloo et al. (2006) and contains four sets of interval data for each branch. No further information is provided concerning the nature of the data besides that the first criteria is a cost criteria (where less is better than more) and the remaining three criteria are benefit criteria (where more is better than less). The WOD procedure is constructed to handle only benefit criteria like a traditional MCDM method. Therefore the sign is changed on all values representing the first criteria. Also, to make it directly comparable data are normalized, see Table 3 in the appendix for the data set.

Analyzing a reduced set of alternatives

For the purpose of illustrating the WOD procedure and the differences between WOD and TOPSIS graphically, we will initially consider only the two first criteria C_1 and C_2 and the 6 bank branches (alternatives): $A_7, A_9, A_{10}, A_{11}, A_{12}$ and A_{14} . The data is taken from Table 3 in the appendix and illustrated in Figure 6. Later we apply the WOD procedure on the full data set.

Table 1 provides rankings of the 6 alternatives with different values of the choice parameters in WOD. The criteria weights are the same in all rankings and they are chosen such that criteria 1 is twice as important as criteria 2. The first four rankings represent WOD with four different sets of choice parameters and the last ranking represents that of TOPSIS. Each of the four WOD rankings demonstrate differences between the way WOD and TOPSIS rank alternatives. In WOD 1-3, $\alpha = 0$ meaning that no alternatives are excluded *a priori*. This makes it easy to compare WOD to TOPSIS directly. In WOD 4, α is strictly positive, which exclude alternatives that are de facto dominated by A_9 , the top ranking alternative with the chosen criteria weights.

First, we notice that for a risk neutral decision maker the ranking of WOD and TOPSIS are not the same (comparing WOD 1 and TOPSIS in Table 1).

Table 1: *Different rankings with same criteria weights*

| Ranking | WOD 1 | WOD 2 | WOD 3 | WOD 4 | TOPSIS |
|---------------|-------|-------|---------|---------|--------|
| W_1 | 2 | 2 | 2 | 2 | 2 |
| W_2 | 1 | 1 | 1 | 1 | 1 |
| α | 0 | 0 | 0 | 0.0001 | n/a |
| β | 0 | 0 | 0.25 | 0.25 | n/a |
| γ | 1 | 13,9 | 13,9 | 13,9 | n/a |
| Rank 1 | A9 | A9 | A9 ~ A7 | A9 ~ A7 | A7 |
| Rank 2 | A7 | A7 | A12 | A12 | A9 |
| Rank 3 | A14 | A12 | A14 | A14 | A12 |
| Rank 4 | A12 | A14 | A11 | | A14 |
| Rank 5 | A11 | A11 | A10 | | A11 |
| Rank 6 | A10 | A10 | | | A10 |

With the chosen criteria weights WOD will never rank $A7$ as the single best alternative unlike TOPSIS. Figure 6 illustrates that both the worst and the best outcome of $A9$ dominates that of $A7$. Hence, according to WOD, $A7$ can never outrank $A9$. At best they can be considered equivalent. In WOD 3, β is set to 0.25, which is the threshold for which $A7$ and $A9$ fall into the same equivalent class.

The role of the choice parameter γ is illustrated in Figure 7. While TOPSIS rank $A12$ above $A14$, WOD requires γ to be larger than or equal to 13.9 in order to produce the same ranking (see WOD 2, 3 and 4 in Table 1). A value of $\gamma = 13.9$ indicates that the decision maker should be highly risk loving to justify the ranking of TOPSIS.

Requiring that α must be strictly positive, as in WOD 4, makes alternatives $A10$ and $A11$ irrelevant. From Figure 6 and 7 it is clear that relative to $A9$, these alternatives are dominated.

Analyzing the full set of alternatives

Consider the full data set. Initially we put equal weights on all four criteria as in the example in Jahanshahloo et al. (2006). Table 2 shows five different rankings of the 15 alternatives with different choice parameters. The first four rankings represent WOD with four different sets of choice parameter values and the last ranking represents that of TOPSIS from Jahanshahloo et al. (2006). Each of the four rankings by WOD represent differences between the way WOD and TOPSIS rank alternatives.

In WOD 1 and 2, no alternatives are excluded *a priori*. The two procedures rank the alternatives almost in the same way. Comparing WOD 1 and TOPSIS, the only differences come from $A7$ and $A3$ as well as $A11$ and $A15$, which in both cases reverse the ranking. However, if $A1$ (the top ranking alternative) is removed from the set of alternatives, $A7$ will also outrank $A3$ according to TOPSIS. This illustrates that the ranking in TOPSIS between any two alternatives depends on the presence of a third alternative as discussed in Section 2.

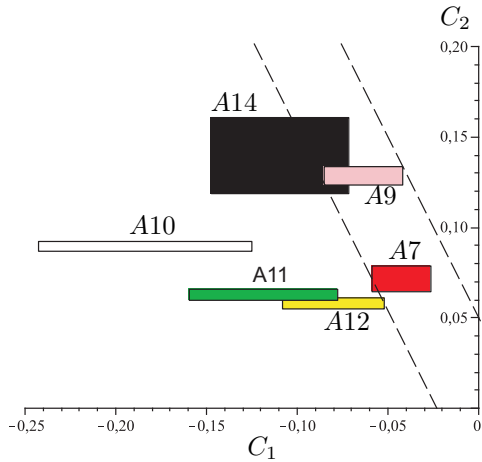

Figure 6: *WOD can not rank A7 above A9*

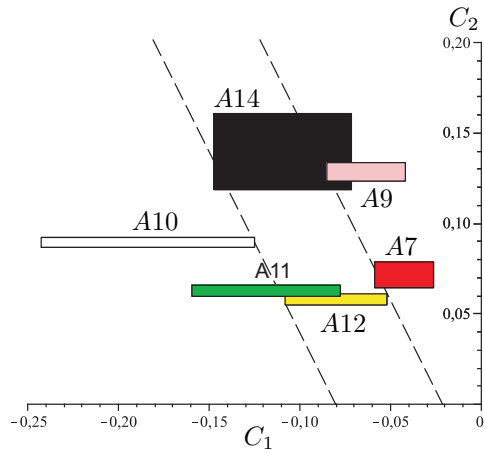

Figure 7: *WOD rarely rank A12 above A14*

In WOD 2, $\beta = 0.5$ which does not change the ranking as such, but creates two equivalent classes. It becomes clear that separating the alternatives $A14, A3, A7, A2$ and $A12$ is less obvious. This is also the case for $A13$ and $A10$.

In WOD 3 and 4, α is strictly positive, which exclude alternatives that are de facto dominated by $A1$ (the top ranking alternative with the chosen criteria weights). This significantly reduces the set of alternatives. Only four undominated alternatives are left. Compared to TOPSIS, the ranking of the three top ranking alternatives $A1, A6$ and $A14$ is the same. However, the fourth ranking alternative, $A2$, rank sixth in TOPSIS. This means that the two alternatives ($A3$ and $A7$) that outrank $A2$ in TOPSIS, are in fact dominated by $A1$ and hence considered irrelevant in WOD. Setting $\beta = 0.5$ as in WOD 4, only makes $A14$ and $A2$ equivalent.

5 The WOD Procedure as Decision Support

By definition (and as illustrated above) the WOD procedure relies on various choice parameters. The field of Multi Criteria Decision Making (MCDM) provides a rich framework for handling the required interaction to settle these choice parameters, for a survey see e.g., Korhonen et al. (1992), Bogetoft and Pruzan (1997) or the more recently Figueira et al. (2005).

Lessons from the MCDM literature are that preferences cannot be expressed in a vacuum and that the focus on more specific alternatives helps defining the preferences in an interactive fashion. Typically, interactive MCDM procedures rely on a progressive articulation of the decision makers preferences. In many MCDM systems such as for instance Pareto Race (Korhonen and Wallenius (1988)), the idea is therefore to let the user gradually learn about best alternatives. Typically, the decision maker interacts with a computer program (the analyst) in order to select the preferred alternative. The approach is illustrated in Figure 8.

Table 2: *Different rankings with same criteria weights*

| Ranking | WOD 1 | WOD 2 | WOD 3 | WOD 4 | TOPSIS |
|----------------|-------|--------------------------|----------|----------|--------|
| W_1 | 1 | 1 | 1 | 1 | 1 |
| W_2 | 1 | 1 | 1 | 1 | 1 |
| W_3 | 1 | 1 | 1 | 1 | 1 |
| W_4 | 1 | 1 | 1 | 1 | 1 |
| α | 0 | 0 | 0.000001 | 0.000001 | n/a |
| β | 0 | 0.5 | 0 | 0.5 | n/a |
| γ | 1 | 1 | 1 | 1 | n/a |
| Rank 1 | A1 | A1 | A1 | A1 | A1 |
| Rank 2 | A6 | A6 | A6 | A6 | A6 |
| Rank 3 | A14 | A14 ~ A3 ~ A7 ~ A2 ~ A12 | A14 | A14 ~ A2 | A14 |
| Rank 4 | A7 | A9 | A2 | | A3 |
| Rank 5 | A3 | A5 | | | A7 |
| Rank 6 | A2 | A11 | | | A2 |
| Rank 7 | A12 | A15 | | | A12 |
| Rank 8 | A9 | A13 ~ A10 | | | A9 |
| Rank 9 | A5 | A4 | | | A5 |
| Rank 10 | A11 | A8 | | | A15 |
| Rank 11 | A15 | | | | A11 |
| Rank 12 | A13 | | | | A13 |
| Rank 13 | A10 | | | | A10 |
| Rank 14 | A4 | | | | A4 |
| Rank 15 | A8 | | | | A8 |

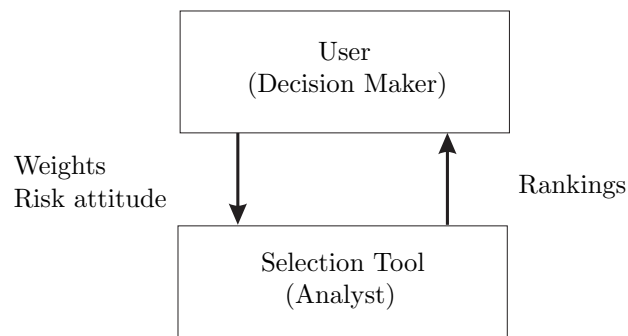

Figure 8: *Progressive articulation of preferences*

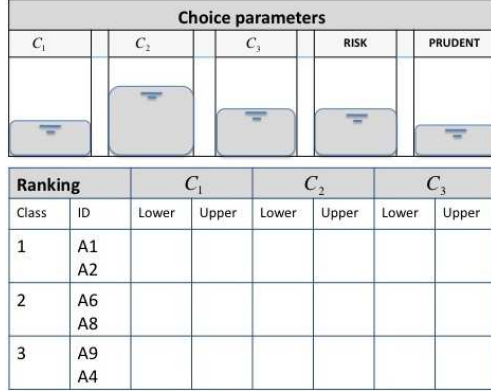

Figure 9: With one set of interval data per criteria

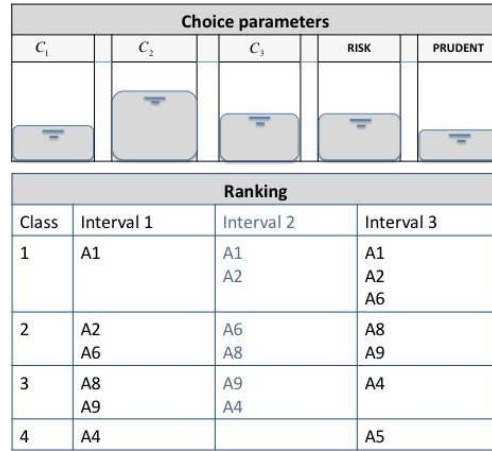

Figure 10: With more sets of interval data per criteria

As such, the WOD procedure can naturally be imbedded in an iterative process where the decision maker expresses his preferences through choice of the various parameters used in the WOD procedure and the analyst replies with a new ranking of the alternatives. Hereby, the procedure allows the user a considerable flexibility and learning support. The user can change his preferences (choice parameters) as he goes along and his implicit articulation of preferences is facilitated by the gradual ranking of alternatives.

Even with as few as 15 alternatives, as in the applied data set, a well-designed interface is crucial for a successful interaction between the user and the WOD procedure. Below, we discuss how to ease the communication with the user.

First, we consider the situation with a single set of interval data for each decision criteria, as in all of the examples above. Second, we consider situations with two or more sets of interval data for each decision criteria, i.e. a situation with more detailed information about the underlying data distribution as discussed in Section 1. From the user's point of view WOD returns simple ordered rankings of the most relevant alternatives given the selected choice parameters and interval data. We illustrate how this simplicity can be reflected in the user interface.

Consider the situation with a single set of interval data for each decision criteria—a situation where the result is a single ranking of all non-excluded alternatives. Figure 9 provides a simple user interface, where the alternatives are ranked in equivalence classes and where the user may change the most relevant choice parameters. The user is given the opportunity to change the weights (w), the risk attitude (γ) and the weighted dominance (β) by simply dragging the bars in the screen interface. Hereby, the user makes sure that the ranking is consistent with the user's risk preferences by adjusting the "Risk" bar and the "Prudent" bar allows the user to control how sensitive the ranking should be by introducing equivalent classes.

Now, consider the situation with multiple sets of interval data for each decision criteria—a situation where the WOD procedure is applied to each set of interval data and the aggregated

result consists of multiple rankings of all non-dominated alternatives. Figure 10 provides a simple user interface, where the resulting rankings of alternatives are presented side by side. As in Figure 9 the user may change the most relevant choice parameter by dragging a bar. Figure 10 illustrates how the ranking of alternatives can change when applied to different levels of interval data. Here "interval 2" represents the one from Figure 9 and interval 1 and 3 are respectively a more narrow and a broader interval. As the interval becomes broader the outranking procedure tends to select more alternatives and cluster them into larger equivalence classes, as illustrated in Figure 10. Marking the changes in the ranking for the top search results provides an easy overview of sensibility with respect to data uncertainty.

6 Final Remarks

To sum up, we introduced a new outranking method for interval data, dubbed WOD. We further argued that WOD have several advantages over existing methods in case of high data uncertainty. For instance, WOD makes pairwise comparisons where the ranking between two alternatives is independent of the presence (and thereby also the uncertainty) of other alternatives in the choice set, and WOD explicitly includes a decision parameter reflecting the decision makers risk attitude. We suggest that WOD is imbedded in a decision support framework enabling a progressive articulation of the decision makers preferences through a sequential choice of parameters and intermediary solutions.

Finally, a few remarks on potential real world application of WOD. As mentioned, the most relevant field of application for WOD is connected with high data uncertainty. Lack of precise information may come from the nature of the problem itself or it may come from lack of time and resources to collect and analyze data. A good example of a potential application for WOD could therefore be decision support for investors looking for investment opportunities for placing early seed capital in new Startup companies. Investing seed capital in a Startup is particularly uncertain and the available data is typically available in the form of interval data e.g., as the range between pessimistic and optimistic estimates of budgets and various key numbers. In particular, the emerging market for "crowdfunding", where many investors invest small amounts, is a relevant field of application. The investors in such a market are typically little experienced and little informed about the details of the individual Startups. Therefore, a systematic and intuitive way of selecting good alternatives is required. One example of a such a market is www.growvc.com.

References

- Bogetoft, P. and Pruzan, P.: 1997, *Planning with Multiple Criteria*, Copenhagen Business School Press.
- Brans, J. and Vincke, P.: 1985, A preference ranking organisation method: (the promethee method for multiple criteria decision-making), *Management Science* **31**(6), 647–656.

- Chen, S.-J. and Hwang, C.-L.: 1992, *Fuzzy multiple attribute decision making. Methods and applications*, Springer-Verlag.
- Figueira, J., Greco, S. and Ehrgott, M.: 2005, *Multiple criteria decision analysis: state of the art surveys*, Springer.
- Jahanshahloo, G., Lotfi, F. H. and Davoodi, A.: 2009, Extension of topsis for decision-making problems with interval data: Interval efficiency, *Mathematical and Computer Modelling* **49**, 1137–1142.
- Jahanshahloo, G., Lotfi, F. and Izadikhah, M.: 2006, An algorithmic method to extend topsis for decision-making problems with interval data, *Applied Mathematics and Computation* **175**, 1375–1384.
- Korhonen, P., Moskowitz, H. and Wallenius, J.: 1992, Multiple criteria decision support - a review, *European Journal of Operational Research* **63**, 361–375.
- Korhonen, P. and Wallenius, J.: 1988, A pareto race, *Naval Research Logistics* **35**, 615–623.
- Opricovic, S. and Tzeng, G.: 2004, Compromise solution by mcdm methods: A comparative analysis of vikor and topsis, *European Journal of Operational Research* **156**(2), 445–455.
- Opricovic, S. and Tzeng, G.: 2007, Extended vikor method in comparison with outranking methods, *European Journal of Operational Research* **178**(2), 514–529.
- Roy, B.: 1972, La method electre ii, sixieme conference internationale de recherche operationelle, Dublin.
- Roy, B.: 1996, *Multicriteria methodology for decision aiding*, Kluwer Academic Publishers.
- Sayadi, M. K., Heydari, M. and Shahanaghi, K.: 2009, Extension of vikor method for decision making problem with interval numbers, *Applied Mathematical Modelling* **33**, 2257–2262.
- Sun, C.-C.: 2010, A performance evaluation model by integrating fuzzy AHP and fuzzy TOPSIS methods, *Expert Systems with Applications* **37**(12), 7745–7754.
- Téno, J. L. and Mareschal, B.: 1998, An interval version of promethee for the comparison of building products' design with ill-defined data on environmental quality, *European Journal of Operational Research* **109**, 522–529.

7 Appendix

The applied data is given in Table 1 in Jahanshahloo et al. (2006) and covers 15 bank branches each represented by four financial ratios (criteria C_1 to C_4). Each criteria is represented by a single set of interval data (Upper and Lower values). Table 3 below, provides the applied normalized data where the sign is changed on the first criteria, such that all four criteria can be treated as benefit criteria (where more is better than less).

Table 3: *The applied data set. Source: Jahanshahloo et al. (2006).*

| Bank branch | C_1 | C_2 | C_3 | C_4 |
|--------------------|---------------|-------------|-------------|-------------|
| A1 Upper | - 0.164534481 | 0.600187091 | 0.286550607 | 0.508665906 |
| A1 Lower | - 0.085636246 | 0.517686651 | 0.197485759 | 0.07062422 |
| A2 Upper | - 0.303869448 | 0.203708251 | 0.376843937 | 0.232058216 |
| A2 Lower | - 0.149530125 | 0.197236868 | 0.028397379 | 0.167063637 |
| A3 Upper | - 0.033611332 | 0.232938502 | 0.201096293 | 0.037355231 |
| A3 Lower | - 0.016418021 | 0.219827204 | 0.172017257 | 0.015205881 |
| A4 Upper | - 0.299960477 | 0.075866284 | 0.009086263 | 0.006748259 |
| A4 Lower | - 0.145143657 | 0.075033416 | 0.003685442 | 0.004629466 |
| A5 Upper | - 0.02061794 | 0.03182867 | 0.135290179 | 0.027110746 |
| A5 Lower | - 0.01004455 | 0.027814624 | 0.135230253 | 0.012910157 |
| A6 Upper | - 0.163548681 | 0.079930813 | 0.364371861 | 0.430084882 |
| A6 Lower | - 0.079478419 | 0.078346655 | 0.303666939 | 0.340316225 |
| A7 Upper | - 0.058684199 | 0.078781228 | 0.336581232 | 0.183268232 |
| A7 Lower | - 0.026577238 | 0.064316495 | 0.253164398 | 0.040961858 |
| A8 Upper | - 0.62118069 | 0.147530988 | 0.011378428 | 0.006350528 |
| A8 Lower | - 0.299900576 | 0.134526222 | 0.010764187 | 0.004305579 |
| A9 Upper | - 0.084850687 | 0.133661682 | 0.180586659 | 0.166921068 |
| A9 Lower | - 0.041817776 | 0.12317011 | 0.085529221 | 0.078289306 |
| A10 Upper | - 0.242532488 | 0.092508684 | 0.022135124 | 0.040931882 |
| A10 Lower | - 0.124982676 | 0.086985723 | 0.020367311 | 0.027422204 |
| A11 Upper | - 0.159377857 | 0.065761491 | 0.019603256 | 0.107361653 |
| A11 Lower | - 0.077828573 | 0.05944098 | 0.015101323 | 0.068478376 |
| A12 Upper | - 0.107823594 | 0.060883672 | 0.202774218 | 0.316959061 |
| A12 Lower | - 0.051956456 | 0.054926137 | 0.111746797 | 0.08801177 |
| A13 Upper | - 0.230290426 | 0.066769225 | 0.060262969 | 0.029230269 |
| A13 Lower | - 0.112752594 | 0.061699265 | 0.049558708 | 0.014648766 |
| A14 Upper | - 0.147320632 | 0.160438819 | 0.303052698 | 0.333056911 |
| A14 Lower | - 0.071912061 | 0.118644902 | 0.182961222 | 0.203342656 |
| A15 Upper | - 0.050000259 | 0.023073857 | 0.013101297 | 0.034451945 |
| A15 Lower | - 0.024761381 | 0.02302395 | 0.011191159 | 0.020671021 |