

INSTITUTE OF FOOD AND RESOURCE ECONOMICS
UNIVERSITY OF COPENHAGEN



MSAP Working Paper Series

No. 03/2010

An Allocatively Efficient Market For Payment Entitlements?

Kurt Nielsen

Institute of Food and Resource Economics

University of Copenhagen

Jesper Troelsgaard Nielsen

The Danish National Bank



An Allocatively Efficient Auction Market for Payment Entitlements?

Kurt Nielsen* and Jesper Troelsgaard Nielsen†

Marts 2010

Abstract

We discuss the allocative efficiency of the market for the so-called Payment Entitlements that resulted from EU regulation no 796/2004 of the European agricultural policy. In particular we consider the existing market in Denmark and discuss the design of an allocative efficient auction market. The complexity of the market follows directly from initial construction of the payment entitlements, which resulted in a very large number of different payment entitlements. Although the valuation of the different payment entitlements are highly interrelated, they are separate goods that should be priced separately. We show how this complexity makes an allocative efficient auction market practically impossible and we suggest a simplified auction market that can improve the pricing and the transparency on the market for payment entitlements.

Keywords: Interrelated valuation, double auction, walrasian tatonnement, decoupled agricultural subsidies.

JEL Classification: D44, Q13.

1 Introduction

One of the most radical changes in the European agricultural policy in recent time, is the introduction of the so-called Payment Entitlements (PE) as a tool to decoupling agricultural subsidies. The PEs are basically securities that can be utilized by land users and be traded among land users. This paper deals with 3 aspects of the market for PEs: 1) likely inefficiencies of the present market in Denmark, 2) the complexity of an ideal allocative efficient auction market and 3) a suggestion of a simplified and realistic auction market that can help pricing the PEs and improve the allocative efficiency.

For various reasons agriculture has been heavily subsidized in many countries around the world for quite some time. Typically, this support has been coupled directly to the production of agricultural goods. In the European Union (EU), agricultural subsidies have traditionally been a direct price support (as elsewhere). The consequences have roughly been two-fold: Overproduction and a distorted world

*Corresponding author: Institute of Food and Resource Economics, University of Copenhagen, Rolighedsvej 25C DK-1958 Frederiksberg C, Phone: +45 35332316, E-mail: kun@life.ku.dk.

†The Danish National Bank



Figure 1: The construction of PEs.

market price. The overproduction has mainly been solved by production quotas, while the distorted world market price is of continuous concern, not least to the World Trade Organization (WTO). Agriculture has been part of the WTO negotiations since the Uruguay round in 1986-94. As a result of the global concern about distortions of trade, the WTO has worked for global decoupling of agricultural subsidies. Decoupled subsidies is a system where the subsidies do not affect the prices on agricultural products. Within the EU, the USA, and many other places there have been various reforms aiming at decoupling the agricultural support. See Ritson and Harvey (1997) and Picinini and Loseby (2001) for an overview of these reforms.

The commission regulation no 796/2004 implemented by 2005, is a big step towards a complete decoupled agricultural support within the EU. The reform basically states how the PEs should be constructed and used. The basic allocation principle was one PE to one hectare at each *land user* (land user cover both holders of farm as well as non-farm land). The initial allocation of PEs consisted primarily of two fundamental different types of PEs: *Set-aside PEs* and *ordinary PEs* as illustrated in Figure 1. At land user level, the number of set-aside PEs was simply given by 8 % of the land¹. The remaining number of hectares stated the number of ordinary PEs.

A set-aside PE had a fixed yearly payment (the nominal value) and the holder was required to use the set-aside PEs before using the ordinary PEs. An ordinary PE does not have a fixed ordinary value per se. As illustrated in Figure 1, ordinary PE was initially divided into PEs/hectares used for permanent grass and other crops. PEs for permanent grass production was given a nominal value of 500 DDK (approximately 67 EURO) and the rest was given the same nominal value as set-aside PEs 2295 DDK (approximately 308 EURO). Furthermore, a supplement of X DDK in the form of decoupled subsidies from e.g. milk and meet production divided by the number of ordinary PEs, was added to all ordinary PEs. In figure 1 this is illustrated by X/Y , where Y is the number of PE/hectares not used for set-aside. Since a large number of land users had a positive X in the applied reference period, this construction principle resulted in a large number of different nominal values of the ordinary PEs. The set-aside PEs was temporarily removed in 2008 and permanently abolished by 2009. The set-aside PEs was simply converted to ordinary PEs with the nominal value given by the construction in 2005.

¹some special arrangement was made for small land users

Clearly, if the PEs have different nominal values, they will have to be treated as separate but highly related goods. In terms of complexity in finding the allocative efficient market prices, the most important factors are the number of different interrelated goods as well as the type of interrelated valuations. As described in more details in the paper, while the number of different PEs is very significant and above 7000 the interrelated valuation is greatly simplified by cancelling the set-aside PEs in 2008.

Some attempts have been made to estimate the outcome of the reform, see e.g. *Impact of the eastern European accession and the 2003-reform of the CAP Consequences for Individual Member Countries* (2003). These studies consider the effects on the decoupled production but not the market for decoupled subsidies. Also, these models rely on ideal assumptions about how the market works, which may not hold in practice².

As briefly mentioned, this paper discusses the market for PEs in general and the Danish market in particular. First, we describe the present situation and the likely inefficiency cause by the way the market is organised. Second, we describe the complexity of designing an allocatively efficient auction market. The complexity is threefold; 1) the computation of the market clearing prices cannot be guaranteed, 2) the required information from the individual participants is very comprehensive and 3) the mechanism may not be fully understood by the participants. Third, we discuss an intermediate solution between the present market and the ideal allocative efficient auction market. We suggest a compulsory single double auction market for the most common type of ordinary PEs, which count for almost half of the total number of PEs. Evidens from the so-called information markets, suggest that the resulting market clearing price from such a market is valuable information to ease the trading of the remaining PEs. Series of experimental studies have shown that consumers' are better at ranking goods relative to their preferences as oppose to state absolute willingness to pay or accept. Therefore, a single market clearing price for the most common type of PE may help the market by providing a focal point for pricing the remaining PEs.

The outline of the paper is as follows. Section 2 describes the market for PEs with particular focus on the Danish market. Section 3 discusses the design of an allocative efficient auction market and a simplified auction market is suggested in Section 4. Section 5 concludes.

2 The Danish Market for Payment Entitlements

In 2005, the Danish market for Payment Entitlements (PE) consisted of approximately 2,8 million PEs that can be utilized only by land users, in the relation one PE to one hectare. The total nominal value (the yearly payment from EU if all PEs are utilized) is approximately 7 billion DKK (approximately 940 millions EURO). The ongoing decoupling of e.g. sugar beet production and the described yearly adjustment, will change the nominal value year by year. In this section we present details about the Danish market. Although the reform has been implemented differently by the EU

²The results in *Impact of the eastern European accession and the 2003-reform of the CAP Consequences for Individual Member Countries* (2003) are based on a general equilibrium model.

members, there are, to our knowledge, many EU members with the same fundamental structure as the Danish.

Before the PEs were introduced in 2005, the farmers received a decoupled subsidy per hectare, and an additional coupled subsidy for e.g. meat and milk production. With the introduction of PEs, almost all subsidies were decoupled. The initial total amount of direct payments was determined by a reference period (2000 - 2002). The EU members could choose two different setups for the PEs: They could either divide the initial total subsidies evenly among the farmers, or they could divide it based on the individual farmers' subsidies in the reference period. Denmark chose the latter. As described in the introduction, there were originally three main types of PEs, two ordinary PEs (permanent grass and other production) and one set-aside PE. Furthermore, some of the PEs for other production had separate conditions related to primarily fruit and vegetable production. However, these conditions were removed by 1. January 2007. As illustrated in Figure 1 in the introduction, the three types of PEs had the following fixed initial nominal values: 500 DKK for permanent grass and 2.295 DKK for other production and the set-aside PEs. Further, the additional subsidies that was coupled to e.g. meat and milk production, have been distributed evenly on the individual farm's PEs for permanent grass and other production. The set-aside PEs, as mentioned, was preliminary converted into ordinary PEs in 2008 and abolished by 2009. The remaining ordinary PEs have different nominal value for a large part, which follows from the fact that most farms differ regarding their production portfolio and number of hectares, as described in the introduction.

Apart from the initial value, the reform describes the adjusted nominal values that the user of a PE receives each year. The reform stated by 2005 a maximum nominal value of 5.000 EURO and a yearly depreciation starting with 3 % in 2005, 4 % in 2006 and 5 % in 2007-2012. Beside these yearly adjustments, the initial nominal value for the three initial types of PEs are equalled during the period 2009-2012. This is done by raising the fixed nominal value of PEs for permanent grass and reducing the fixed nominal value of PEs for other production and set-aside. Nevertheless, it will only reduce the number of different nominal values with one. From 2012 the valuation is subject to a scheduled political decision. The expectations about this political decision is increasingly important for the pricing of the PEs valuation as the time approach.

Clearly, a PE with a high nominal value is worth more than one with a low value, and they should therefore be treated as separate goods. Buyers and sellers of PEs are, of course, concerned about the difference between its price and its value to him, not the price nor the nominal value in itself. Upon knowing the price on each of the PEs for sale, the buyer can relatively easy select his most preferred portfolio of PEs. However, the prices are of course endogenously determined by the individual demand and supply for the various PEs. As we shall explore in more details, the actual number of different PEs is the most important parameter for the complexity of this searching and matching process.

Figure 2 shows how the Danish PEs are distributed by their nominal value in the range 0-7.000 DKK. To get a better picture, the 1 % of the PEs that have a nominal value greater than 7.000 DKK is

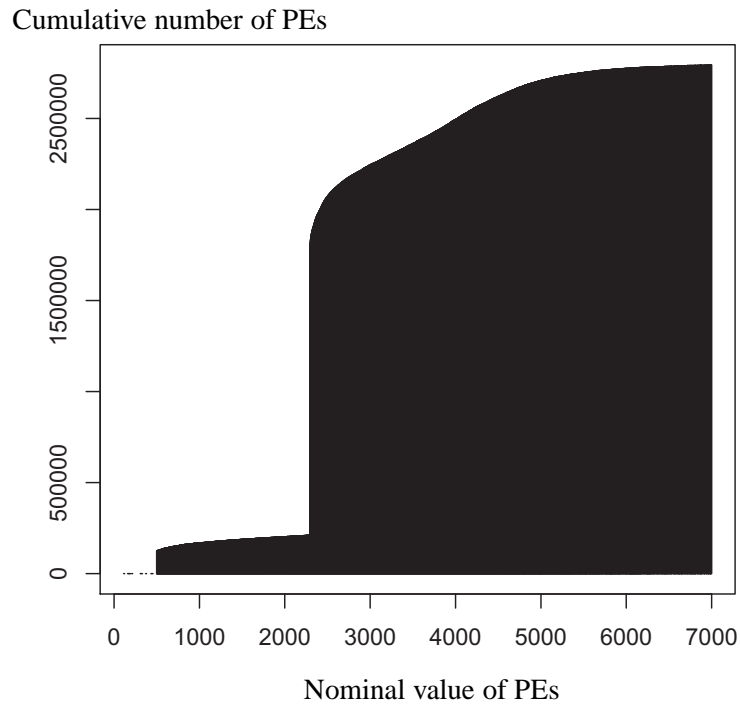

Figure 2: Distribution of PEs by their nominal value.

left out³. Most PEs have a nominal value of about 2.295 DKK, i.e. the standard nominal value of ordinary (apart from permanent grass) and the original set-aside PEs. Out of the total number of PEs, 6,7 % was original set-aside PEs. The number of different nominal valuations (the number of discrete jumps in Figure 2) is 7.793. To put this number into perspective, The New York Stock Exchange has listed 2.764 securities, each priced with a single unit price on a continuous trading (continuous double auction)⁴. However, if we group the PEs in intervals of 10 DKK the number is reduced to 1.815 and further to 374 if the interval is 100 DKK. Anyhow, the required number of different unit prices to clear the market is very significant.

In Denmark, the PEs may be traded freely among land users with or without land. The weak definition of land user is given as a person that produces agricultural goods or maintain land in a good agricultural and environmental condition. In Denmark, the trade of PEs is decentralized in the sense that farmers trade directly with each other or through a local broker. In terms of statistics, there is no central registration of prices as opposed to quantities that are registered by the government. Table 1 provides the total number of trades divided into the two categories: Permanent and temporary reallocation. Temporary reallocation is mainly used in relation to leasing contracts.

It is common knowledge that permanent reallocation mainly concern situations where land are traded, around 90 % of all trades involves both PE's and land⁵. However, the number of trades in table 1 is significantly higher than 90 % of the average trade of land. For the years 2001-2004, around 5.900 farms and 110.000 ha have been traded on average per year and the total area has decreased with around

³Ministry of Food, Agriculture and Fisheries (2007) has provided the data.

⁴www.wikipedia accessed 11 February 2008.

⁵This is common knowledge among local farm property consultancies.

Table 1: Reallocation of PEs in the period 2005-2007 (2007 only Jan-Apr).

	Number of PEs		Number of trades	
	Temporary	Permanent	Temporary	Permanent
2005	78.999	124.540	4.036	4.298
2006	214.057	271.425	10.416	9.522
2007	52.954	71.207	2.887	2.943

9.000 ha per year, see (De Danske Landboforeninger 2004)⁶. There are several reasons for this relative high number of trades.

First, the PEs was not assigned before the end of 2005 and 80 % of the assigned PEs was required to be used at least once before selling them without land⁷. This may explain the lower number of trades in 2005 compared to 2006. Furthermore, before 2005 the number of leasing contracts dropped, because of doubts about who would receive the PEs, see Dansk Landbrug (2007). These land users could in 2006 trade back the PEs as temporary trades. Those leaseholders that received the PEs in 2005, because they controlled the land, may in 2006 have permanently traded back the PEs. This may have resulted in PEs being traded from the leaseholder to the owner permanently, and afterwards, back to the leaseholder for a temporary period.

Second, by the reform the subsidies is coupled to land. This coupling introduced "new agricultural land" that had never been registered before. In Denmark the total agricultural land has decreased for several decades apart from a significant increase from 2004 to 2005, where it increased by 2,3 %. The most significant component is the so-called "other crops" that increased with approx. 1.000 % from a steady level in 30 years. Furthermore, some land users are not registered in the agricultural statistics. Approximately 69.500 land users received PEs in 2005 though only 51.676 was registered as farms, see Danish Statistics (2006). This new agricultural land may very well have caused some extra trades of PEs shortly after 2005, see Danish Statistics (2006).

Finally, the set-aside PEs have been traded relatively more than ordinary PEs. The reason for this is most likely that set-aside PEs work as production constraints and that the increasing prices on some crops have lowered the price on set-aside PEs. We have reported land users who actually paid others to take set-aside PE's. Since any land user can buy as many PEs as he like, a land user that set-aside all of his land can "buy up" the set-aside PEs.

Today, the PEs are traded bilaterally or by small brokers in a decentralized market. In this bilateral trade regime, individual land users search the market and negotiate prices on a bilateral basis. This allows for some attractive transfers but suffers from several problems.

The first problem is that of finding the right trading partners and number of PEs. The direct search

⁶Eventhough we do not have the latest statistics on the trade of land, we expect the numbers to be a good approximation.

⁷The Directorate for Food, Fisheries and Agri Business: www.netpublikationer.dk/DFFE/3133/html/chapter06.htm accessed 13 February 2008.

costs (time, advertising and so on) may be considerable. Likewise, the indirect costs of, for example, ending up with a suboptimal portfolio of PE may be significant.

The second problem is that of imperfect information. Bilateral trade has to be settled among land users with private information about the valuation of various types of PEs. Simple Bayesian bargaining models have demonstrated how sellers will overstate and buyers understate values, often to the extent that no trade is realised, even when in reality the buyer values a given PE more than the seller. As emphasised by (Myerson and Satterthwaite 1983), delays and failures are inevitable in private bargaining.

The third problem is that of possible uneven bargaining power. Experimental studies show that bilateral trade in a market with many buyers and sellers tends to empower the sellers and result in prices that are higher than the competitive prices. This result was first shown in Ketcham et al. (1984). Non-competitive prices will result in inefficiency and most likely lower traded quantities.

In conclusion, it is unlikely that the present bilateral trade regime will suffice to realise the potential gains from reallocation. The increased complexity from the lack of transparency and the high number of different PEs with interrelated valuations make the convergence towards an allocative efficient allocation unlikely. The required coordination is further emphasized by the discussion of an ideal auction market in Section 3.

3 An Allocative Efficient Auction Market

An allocative efficient auction market allocates the different PEs to those that value them the most⁸. Such an ideal market would maximize social welfare and attracts all the trade. To see this, note that if the price for a given PE is lower on the ideal central market for PEs, the ideal market would attract the buyers. Likewise if the price is higher, the ideal market attracts the sellers. In this section we explore whether such an ideal auction market is feasible.

3.1 A Single Double Auction

Assuming that the different PEs could be treated as a single good, the double auction institution will likely be the most efficient trading institution to settle the ideal single market clearing price. This is supported by the brief literature review below.

An auction is basically a set of trading rules that aim at improving the allocation of goods and services. The crux in designing auctions is to find the rules that best guarantee the desired outcome, e.g. by introducing a price setting mechanism that leads to more profitable trading by concentrating the market, or by making the market more transparent. For a comprehensive survey on auctions see e.g. Klemperer (1999).

There exists a tremendous literature on auctions but only a relatively small fraction of this considers *multi-unit double auctions* where sellers and buyers reallocate multiple units of a single

⁸Since different land users have different valuations of the same PE, an allocation that maximizes the total subsidies does not necessarily coexist with an allocative efficient allocation.

product or service. These auctions are sometimes called exchanges, we will refer to them simply as double auctions or two-sided auctions. Some of the most important real world markets are double auctions, e.g. power or stock exchanges.

To thoroughly study a double auction one needs an equilibrium model. Attempts have been made to introduce strategic behavior in the analytical studies of double auctions by invoking a series of further simplifications, see e.g. Wilson (1985) and Amir et al. (1990). However, in general, the problem of solving for equilibria in multi-unit auctions is analytically intractable, Gordy (1999, p. 450).

The literature on double auctions focuses in particular on three problems: 1) incentive compatibility (i.e. truth-telling must be an optimal bidding strategy), 2) ex post efficiency (i.e. the realization of all trades that improve social welfare) and 3) budget balancing (i.e. aggregated value sold must equal aggregated value bought). The two first problems follow from the so-called Myerson-Satterthwaite theorem, (Myerson and Satterthwaite 1983). It says that delays and failures are inevitable in private bargaining if the goods start out in the wrong hands. This follows from the central observation that in any two-persons bargaining game the seller has incentives to exaggerate the value and the buyer has incentives to pretend the value is low. There have been a few attempts to design truth-telling double auctions, see McAfee (1992) and Yoon (2001, 2003). Attempts to solve the first two problems are typically at the cost of the third problem of balancing the budget. Fortunately, the magnitude of the three problems diminish as the number of participants grows.

This paper considers markets that are two-sided and have a large number of participants. We therefore assume that the buyers and sellers are non-strategic price-takers. They do not speculate in the price effect of demand and supply reductions. This assumption can be justified by several observations. First, this is a two-sided auction with elastic supply and demand. Any attempt to influence the price has a smaller effect in a two-sided auction than a one-sided auction with in-elastic supply. Second, we consider a market with a large number of participants. This makes every participant marginal. Third, several empirical studies and laboratory experiments have shown double auctions to be very stable, i.e. they are robust against strategic behavior. Test auctions with as few as 2-3 buyers and 2-3 sellers have generated almost efficient outcomes (Freidman (1984) and Friedman and Ostroy (1995)). Fourth, Satterthwaite and Williams (1989) analytically show that a double auction modeled as a Bayesian game converges rapidly towards ex post efficiency as the market grows. Other contributions along this line are Satterthwaite and Williams (2002) and Cripps and Swinkels (2005).

Consider a large number of sellers and buyers that meet in a double auction to exchange multiple items of a good. The sellers have well-defined supply schemes represented by a set of quantity-price bids $(s_1, p_1), (s_2, p_2), \dots, (s_L, p_L)$. Here, s_i is the quantity seller i offers for sale at p_i . In this general representation, the supply scheme consists of L bids, one for each of the L possible bid prices. Likewise the buyers have well-defined demand schemes represented by a set of quantity-price bids $(d_1, p_1), (d_2, p_2), \dots, (d_L, p_L)$. The demand and supply schemes are assumed to be monotone in the price. That is, for any two prices p_h and p_l where $p_h \leq p_l$ we have $s_h \leq s_l$, i.e., a seller will supply at

least the same when the price increases, and $d_h \geq d_l$, i.e. a buyer will demand at least the same when the price falls. All trade is executed at the same market clearing price. Bids to buy above and sell below the market clearing price is accepted, the remaining bids are rejected.

Now the aggregated demand/supply is found by summing up the demand/supply for each feasible market clearing price. Let I be the number of buyers, J the number of sellers, and i and j be the associated counters. For any market clearing price p_l , $l = 1, 2, \dots, L$, the aggregated demand is given by $AD_l = \sum_{i=1}^I d_l^i$ and the aggregated supply is $AS_l = \sum_{j=1}^J s_l^j$. Also the excess demand is defined as $Z_l = AD_l - AS_l, \forall l = 1, 2, \dots, L$. The discrete nature of the bids requires a clearing policy. We will typically say that an (approximate) equilibrium is where Z_l is closest to zero. With price-taking behavior the optimal bidding strategy is simply to submit the true demand and/or supply schemes, see e.g. Nautz (1995).

3.2 More Simultaneous Double Auctions

As discussed above, the PEs cannot be treated as a single good. The market for PEs is a market for multiple interrelated goods. It is well known that the nature of the interrelation is crucial for the optimal market design. The fundamental difference is whether the goods are substitutes or complements.

PE_A and PE_B are substitutes if the cross price elasticity of demand is positive. Meaning that a relative increase in the price of e.g. PE_A causes an increase in the demand for PE_B . For a larger number of PEs, mutual substitutability maybe defined differently as⁹: For any land user i and any k , if raising the prices on all PEs but PE_k (PE_{-k}) does not reduce the demand for PE_k :

$$p_{-k}^* \geq p_{-k}, p_k^* = p_k \quad \Rightarrow \quad D_k^i(p^*) \geq D_k^i(p) \quad (1)$$

It seems reasonable to assume that the different ordinary PEs are mutual substitutes. To see this, note that the important measure for choosing an ordinary PE is the difference between the value to the land user's of the ordinary PE and its price. Now, since any land user may use any ordinary PE, a price increase of one PE will not reduce the demand for other PEs.

On the other hand, PE_A and PE_B are complements if the cross price elasticity of demand is negative. Meaning that a relative increase in the price of e.g. PE_A causes and decrease in the demand for PE_B .

Set-aside PEs and ordinary PEs may be complements. Since the use of set-aside PEs are compulsory, a land user's valuation of an ordinary PE may be conditioned on whether he can sell the set-aside PEs. The complementary effect may come from a relative increase in the price of set-aside PEs, which lower the demand for these and because set-aside PEs was required to be used before ordinary PEs, this may result in a negative effect on the demand for ordinary PEs. However, with the permanent abolishment of set-aside PEs by 2009, the interrelated valuation of PEs are most likely reduced to mutual substitutes only.

⁹See e.g. Milgrom (2004) for more.

The interrelated valuations of the different PEs add a new layer of complexity to the auction design. Among other places, these issues have been widely discussed in relation to selling licenses for using radio spectrums in the US. If a city is divided into two licenses, having both of the licenses is worth far more than the separate values of the two. On the other hand, the value of two spectrum licenses for two different cities may very well be independent. This problem of handling goods that can be complementary as well as substitutes on the same market is not an easy task. The general approach, known as combinatorial auctions, allows the bidders to bid on any combination of items. Defining one's strategy is therefore an overwhelming task. Also, the auctioneer's tasks of selecting winners and setting the prices is complex. In general, the problem of solving a combinatorial auction is so-called NP-hard¹⁰. This means that the number of "elementary operations" (like addition, subtraction, etc.) increases faster than any polynomial function of the number of bidders, the number of goods etc. For practical purposes, this means that there is no guarantee that a solution will be found. Fortunately, most combinatorial problems can be solved by restricting the permissible combinations or by applying heuristics that find "reasonable" solutions. For a survey on combinatorial auctions, see Vries and Vohra (2003). The use of combinatorial auctions is still very limited, for more see e.g. Cramton et al. (2006). All existing applications concern a small number of different goods and bidders. The market for PEs consist of a large number of both different PEs and bidders, which makes it NP-hard to guarantee an allocative efficient solution.

As mentioned above, we will assume that the abolishment of set-aside PEs have reduced to coordination to concern only goods that are mutual substitutes. Hereby, the searching for equilibrium prices is greatly simplified and the optimal equilibrium may be found by a so-called Walrasian Tatonnement Walras (1874). Unfortunately, the price development in a Walrasian tatonnement with more than two goods is not monotonic over iterations, and the process is not guaranteed to end in a finite number of steps Milgrom (2004). The large number of possible equilibria illustrates the difficulties in finding the equilibrium. With K different PEs, an equilibrium is the K market clearing prices that clear all markets. Let L be the number of possible market clearing prices on each of the K markets (as in the example of a single double auction in Section 3.1). Now the total number of equilibrium candidates are $L_1 \cdot L_2 \cdot \dots \cdot L_K = L^K$. In fact, computing the equilibrium is NP-hard in the number of markets. Nevertheless, a separate line of research has shown that the systematic price formation makes it possible to design good algorithms that approximate the equilibrium in reasonable time, see e.g. Cheng and Wellman (1998); Cheng et al. (2003). This work shows that computing such equilibria is feasible¹¹.

Now, consider the particular market for PEs. We consider a sealed bid auction with discrete clearing as described above. Hereby, the participants submit the required information once and the central planner coordinate the trading based on this information. This is basically done by an iterative

¹⁰NP-hard (Non-deterministic Polynomial-time hard) denotes a problem whose solution algorithm can be translated into one for solving any NP problem. An NP-hard problem is at least as hard as, but may be harder than, any NP problem (Weisstein 1999).

¹¹For more on the performances, see the so-called Trading Agent Competition at www.sics.se/tac (accessed February 2008).

process where the central planner computes the buyers' and sellers' myopic best response to a given equilibrium candidate until the markets clear.

In the following, we will define this myopic best response to a given equilibrium candidate. For simplicity we will assume that the farmers have constant marginal utility of subsidies¹² (money) and that the administrative costs of handling a PE is negligible. Hereby we effectively assume that willingness to accept (WTA) or willingness to pay (WTP) for a given type of PE can be represented by a single number. Now, let R_k^i be bidder i 's WTA or WTP of PE_k , then the expected surplus from buying a PE_k is given as:

$$V_k^i = R_k^i - \hat{p}_k \quad (2)$$

where \hat{p}_k is the market clearing price. Likewise, the surplus from selling a given PE can be determined. Based on the surpluses from buying and selling, the most optimal portfolio of PEs can be determined subject to an equilibrium candidate. Let \mathbf{q}^i be a vector with the number of each of the K different PEs in i 's portfolio, Q^i the total number of PEs and n^i the number of hectares. With constant marginal utility of money, the participants' most preferred portfolios are subject to the following four constraints:

Buying constraint: Buy only the most valuable PEs (given that it generates a positive surplus):

$$V_{k^*}^B = R_{k^*} - \hat{p}_{k^*}, \text{ where } k^* = \arg \max_{k=1,2,\dots,K} \{R_k - \hat{p}_k\}$$

Selling constraint: Sell only PE_k if the surplus from selling is positive: $V_k^S = \hat{p}_k - R_k > 0$

Replacement constraint: Replace only existing PEs if the total surplus from replacing is positive:

$$V_k^{TS} = V_{k^*}^B + V_k^S > 0$$

Quantity constraint: The reservation values of the PEs that are not utilized (because the number of PEs exceed the number of hectares is set equal to 0

Now the actual demand and supply can be determined. By setting the reservation values of PEs that are not utilized equal to 0, the supply of PEs is given by the replacement constraint. Supply is a vector \mathbf{s}^i with the number of PEs that provides a positive total surplus:

$$\mathbf{s}^i = \left\{ \begin{array}{ll} q_k^i & \text{if } V_k^{i,TS} > 0 \\ 0 & \text{otherwise} \end{array} \quad \forall k = 1, 2, \dots, K \right\} \quad (3)$$

Based on this optimal supply the demand is simply a matter of utilizing the number of ha (given that $V_{k^*}^B > 0$). Based on the supply \mathbf{s}^i the demand is given by the following number of PE_{k^*} :

$$d_{k^*}^i = n^i - \left(Q^i - \sum_{k=1}^K s_k^i \quad \text{if } V_{k^*}^{i,B} > 0 \right) \quad (4)$$

¹²Although it might be difficult to communicate, a decreasing marginal value of money could easily be included.

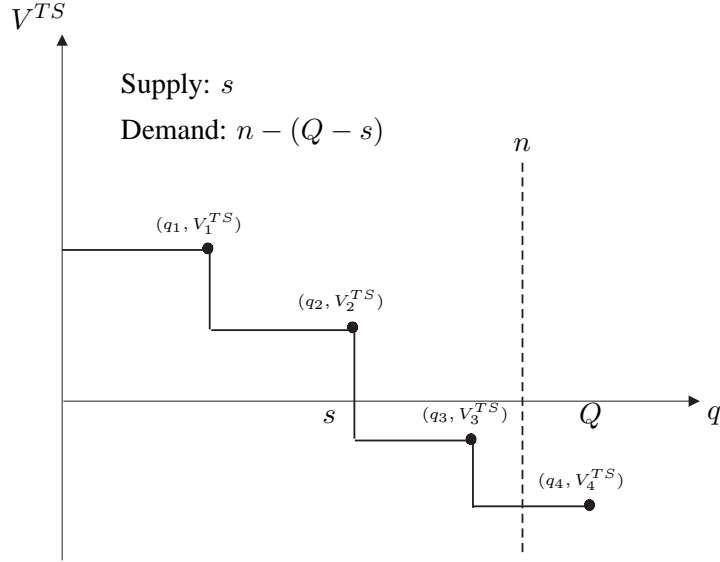

Figure 3: Supply and demand based on total surplus V^{TS}

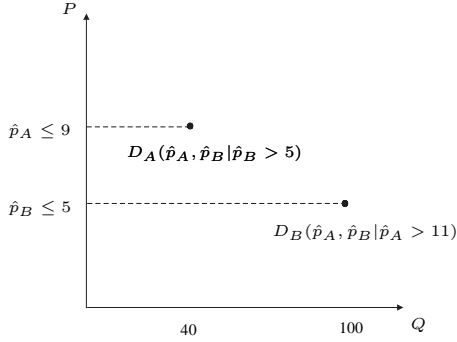

Figure 4: Conditional demand of PE_A and PE_B

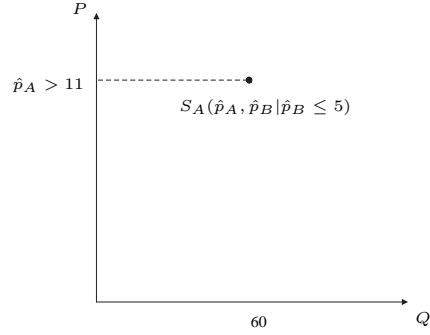

Figure 5: Conditional supply of PE_A

To picture this in a figure, let i 's surplus scheme from trading (total surplus) be the order-statistics of $(q_1^i, V_1^{i,TS}), (q_2^i, V_2^{i,TS}), \dots, (q_K^i, V_K^{i,TS})$ with respect to the total surplus $V_k^{i,TS}$. Figure 3 illustrates a situation where s PEs are supplied (two different types of PEs) and $n - (Q - s)$ of the most profitable PEs are demanded.

To give an numeric example, consider farmer i with 100 ha and 60 PEs of type A and a market that consists of only two types: A and B. i 's reservation values are: $R_A = 10, R_B = 6$ and the market clearing prices are: $\hat{p}_A = 8, \hat{p}_B = 5$, which leaves i with $V_A = 2$ and $V_B = 1$ from buying. Since the total surplus of replacing the existing 60 PEs is 0 ($V_A - V_A$), there will be no replacements. Also, since V_A is larger than V_B and positive the demand is simply the number of ha minus number of PEs in i 's portfolio (minus possible replaced PEs): $100 - (60 - 0) = 40$ PE_A .

To picture the demand of e.g. type B in a traditional price-quantity diagram, we need to condition the demand on the price of type A and vice versa. Given $\hat{p}_B > 5$, i will demand 40 PE_A at a maximum of $\hat{p}_A = 9$. Also, he would be willing to sell the existing 60 PE_A at a price just above 11 conditioned on buying 100 PE_B at a price no larger than 5. Figure 4 illustrates farmer i 's conditional demand of both PE_A and PE_B . Figure 5 illustrates the conditional sale of 60 PE_A .

By an efficient Walrasian Tatonnement, the markets for the different PEs are linked together and function as one big market for PEs. In terms of competition, the linkage makes the individual buyer and seller very marginal and, therefore, renders strategic behaviour unlikely. To see this, consider a large buyer that tries to bias the price downwards by withholding demand of a given PE. Now, since the buyers simultaneously bid on all PEs, a lower price on one market will make this PE more attractive to all the other buyers, and some buyers may switch demand towards this market. Likewise, on the other side of the market, consider a large seller who tries to bias the price upwards by holding back supply of a given PE. Again, since the buyers simultaneously bid on all PEs, a higher price on one market will switch demand towards the other markets which counteract any strategic behaviour. Hereby, supported by the studies presented in Section 3, it is reasonable so conclude that the optimal strategy is to provide the auctioneer with truthful information.

Hereby, we can make the observation that the above coordination ensure *individual rationality* and *incentive compatibility*. With no negative surplus from trade *individual rationality* is ensured (participation is a weakly dominating strategy). Also, by selecting the most preferred buys, sells and replacements, *incentive compatibility* is maintained.

For practical use, an important requirement is that the auction is understandable to the user and as simple as possible¹³. While the idea of comparing the different PEs in a Walrasian Tatonnement is (probably) by intuition easy to understand, the primary concern is the required information. In order to act in the best interest of the individual participants, the central planner needs information about every participants' portfolio of PEs, number of ha and not least reservation values (willingness to accept and willingness to pay) of all possible PEs.

In particular, the assumption that WTA/WTP is independent of the number of PEs supplied/demanded - that demand/supply for a given PE can be represented by a single number - is critical. For several reasons, the land users may have a decreasing valuation of PEs. Apart from a decreasing marginal value of money, another reason may come from risk aversion and financial constraints. Risk aversion may be a very likely response to the uncertainty about the whole existence of the agricultural subsidies. Also, financing the total purchase may cause a decreasing marginal value by an increasing cost of financing the total purchase of PEs. Furthermore, the national tax system, e.g. possible tax deduction or taxation of sale, may have significant influence as well. Finally, a PE is not a requirement for production, therefore, the pricing of a PE should include an alternative use of the money¹⁴, which may very well depend on the total amount. In general, for the central planner to find the allocative efficient allocation, the value of any likely combination of PEs is required. Expressing the true demand and supply for hundreds or thousands of PEs a priori seems an overwhelming task.

In conclusion, although the interrelated valuation of PEs can be simplified to be mutual substitutes, the very large number of different PEs significantly complicate the design of an allocative auction

¹³ Understandability is just one of a long list of important criteria. Schotter (1998) provides an overview of general criteria for selecting a mechanism.

¹⁴ Apart from individual investment opportunities, the PEs should compete with the financial market in general.

market. First, the required information from the user is tremendous even in the most simple (but unrealistic) case with constant marginal WTP/WTA. Second, finding the K market clearing price can not be guaranteed even with low number of different markets (K) and K is approximately 8.000, see Section 2. Based on these observations, we conclude that an allocative efficient auction market is unrealistic for practical purposes.

4 A Simplified Auction Market

The previous two sections indicate that the present market for PEs is allocative inefficient and that the design of an allocatively efficient auction market is too complex for practical purposes. In this section we discuss intermediate solutions and suggest a simplified auction market.

As mentioned in Section 2, 90 % of all PEs are sold together with land, which may be natural since the use is coupled to land. Unfortunately, the market for land is by nature a relatively inefficient market due to several things like; low turnover, geographical importance and not least that "land" is sold in bundles with machinery and buildings, etc. Therefore, if the trade of PEs is sold together with land, it is less likely that the PEs are priced according to an otherwise efficient market for PEs. It is a significant risk that either the seller or the buyer will hold up the opponent and bias the price setting of PEs¹⁵. Therefore, even a slightly in-efficient central auction market may be a significant improvement if it decouples the trade of PEs from the trade of land.

Furthermore, the great uncertainty about likely future cuts in or reallocations of the agricultural subsidies, may be leveled by a central market. Experiments and prediction markets have shown that double auctions are efficient in aggregating such information. A prime example of this is the so-called political markets on Iowa Electronic Market. Here, the players are not paid to tell what they vote themselves but rather what they think others will vote, an approach that has outperformed the final Gallup polls, see e.g. Wolfers and Zitzewitz (2004). The prediction is driven by a leveling of the collective expectations about a future event. To some extent, an auction market for PEs may to some extent function as a prediction market about the future agricultural policy in the EU. One of the main differences is that the prediction market is typically held a relatively short period before a given event triggers a certain outcome. The future agricultural policy in the EU will be developed over a longer period of time by politician and opinion-makers who we might not even know today. Nevertheless, if the Danish land users' collective expectations represent the common expectations in present time, a simple double auction provides a leveled measure of this as well as other common components of the value of a PE.

In the previous section we have that the coordination across the different types of PEs makes a central market too complicated for practical purposes. Fortunately, almost half of the PEs on the Danish market are ordinary PEs with the same nominal valuation, as illustrated in Figure 2 in Section 2. The literature and practical experiences suggest that the double auction institution is a very stable and

¹⁵On the other hand, negotiating the price for PEs may be a neglectful part of the collective trade of PEs and land, due to the relative small value of the PEs as opposed to the present market value of land in Denmark.

allocatively efficient auction. Therefore, we suggest to make it compulsory to trade this common type of PEs on a single central double auction. Hereby, half of the PEs are priced on an efficient market, which can improve the allocative efficiency of the entire market for PEs in several ways. First, it can ensure better allocation of the most common type of PEs. Second, it can aggregate the expectations about the common components, e.g. the expectation about the political future of the payment entitlements, as supported by evidences from information markets. Third, it can simplify the pricing of the remaining PEs from absolute pricing to a more simple relative pricing. In a series of experimental studies, Ariely et al. (2003) have shown that although consumers' absolute valuation of experience goods is surprisingly arbitrary the relative ranking appear orderly as if supported by fundamental preferences. In conclusion, in ensuring an efficient pricing of the most common type of PEs, experimental evidence suggest that the pricing and allocative efficiency of the entire market for PEs is greatly simplified.

The pricing of the remaining PEs may follow indirectly from eliciting an efficient market clearing price in the present market for PEs or more directly by other auction institutions. An example of an auction institution relevant for this purpose, is the so-called *simultaneous ascending clock auction* used in the energy and telecom sector, see e.g. Cramton (2003). Here the basic idea is to fix the relative prices among the different goods a priori and let the auctioneer dictate increasing prices until a clearing policy is met. The participants react to the prices by submitting bids/asks in quantities. As for the predetermined relative prices, the market clearing price from the auctioning of the most common type of PE as well as the relative differences in the nominal values of the different PEs, may be used directly. The main challenge, however, is to make it manageable in regarding to the large number of markets and to facilitate a reasonable clearing on each market.

Quantifying the inefficiency of the present market as well as the potential gains from allocative efficient distribution is prevented by lack of information. While quantities are registered by public authorities, price information is almost completely absent. Nevertheless, in qualitative terms, with zero transaction costs involved in the auctioning of the most common type of PEs and with the PEs being mutual substitutes, an allocative efficient market for the most common type of PEs will be weakly better than the existing market, all else equal. However, with no quantitative measure of the inefficiency in the present market and the transaction costs involved in the suggested simplified auction market, no clear answer can be given about the value added.

5 Conclusion

The decoupling of the agricultural subsidies in the EU has introduced an all new market for the resulting securities; the Payment Entitlements (PE). The way the PEs was constructed has resulted in a market for more securities than listed on any stock exchange. Although the pricing of the PEs are highly correlated a large number of interrelated market clearing prices are required to ensure an allocative efficient distribution of the PEs.

The present trading of PEs in Denmark indicates an allocative inefficient distribution. The high

complexity of the market indicates that the bilateral trading is inefficient due to lack of transparency and central coordination of neither information and trades. However, the lack of data about the trading of PEs prevents quantifying the actual inefficiency loss.

The ideal solution is an allocative efficient auction market, where a central planner receives sufficient information to compute allocative efficient market prices and allocate the payments entitlements according to land users' valuations of the PEs. We have illustrated the complexity of designing and running such an allocatively efficient auction market. For practical purposes, this ideal auction market, is prevented by the required information to be send to the central planner as well as the complexity in computing the required allocative efficient market clearing prices.

However, a single compulsory double auction for the most common type of PEs may ease the searching and matching of PEs considerably. An efficient market for the most common type of PEs counts for about half of the PEs. Furthermore, it may ease the market for the remaining PEs in two ways: By aggregating the expectations about common components in the valuations of the PEs and by reducing the pricing of the remaining PEs from absolut to a more simple relative pricing.

Bibliography

- Amir, R., Sahi, S., Shubik, M. and Yao, S.: 1990, A strategic market game with complete markets, *Journal of economic theory* **51**, 126–143.
- Ariely, D., Loewenstein, G. and Prelec, D.: 2003, "coherent arbitrariness": Stable demand curves without stable preferences, *The Quarterly Journal of Economics* **118**(1), 73–105. available at <http://ideas.repec.org/a/tpr/qjecon/v118y2003i1p73-105.html>.
- Cheng, J. Q. and Wellman, M. P.: 1998, The walras algorithm: A convergent distributed implementation of general equilibrium outcomes, *Computational Economics* **12**, 1–24.
- Cheng, S.-F., Leung, E., Lochner, K. M., OMalley, K., Reeves, D. M., Schwartzman, L. J. and Wellman, M. P.: 2003, Walverine: A walrasian trading agent. University of Michigan, Artificial Intelligence Laboratory.
- Cramton, P.: 2003, Electricity market design: The good, the bad and the ugly, Proceedings of the Hawaii Internatinal Conference on System Sciences.
- Cramton, P., Shoham, Y. and Steinberg, R. (eds): 2006, *Combinatorial Auctions*, MIT Press.
- Cripps, M. W. and Swinkels, J. M.: 2005, Efficiency of large double auctions, *Econometrica* **74**(11), 47–92.
- Danish Statistics: 2006, Landbrug 2006 - statistik om landbrug gartneri og skovbrug, *Yearly statistical report*.
- Dansk Landbrug: 2007, *Yearly statistical report*.

- De Danske Landboforeninger: 2004, *Yearly statistical report*.
- Freidman, D.: 1984, On the efficacy of experimental double auctions markets, *American Economic Review* **74**(1), 60–72.
- Friedman, D. and Ostroy, J.: 1995, Competitiveness in auction markets: An experimental and theoretical investigation, *Economic Review* **105**, 22–53.
- Gordy, M. B.: 1999, Hedging winner's curse with multiple bids: Evidence from the portuguese treasury bill auction, *The Review of Economics and Statistics* **81**(3), 448–465.
- Impact of the eastern European accession and the 2003-reform of the CAP Consequences for Individual Member Countries*: 2003, Working paper, Danish Research Institute of Food Economics.
- Ketcham, J., Smith, V. L. and Williams, A. W.: 1984, A comparison of posted-offer and double-auction pricing institutions, *Review of Economic Studies* **51**(4), 595–614. available at <http://ideas.repec.org/a/bla/restud/v51y1984i4p595-614.html>.
- Klemperer, P.: 1999, Auction theory: A guide to the literature, *Journal of Economic Survey* **13**(3), 227–286.
- McAfee, R.: 1992, A dominant strategy double auction, *Journal of Economic Theory* **56**(2), 434–450.
- Milgrom, P.: 2004, *Putting Auction Theory to Work*, Cambridge University Press.
- Ministry of Food, Agriculture and Fisheries: 2007. Data received from Direktoratet for Fødevarer og Erhverv (DFFE), Nyropsgade 30, 1780 Copenhagen V.
- Myerson, R. B. and Satterthwaite, M. A.: 1983, Efficient mechanisms for bilateral trading, *Journal of Economic Theory* **29**(2), 265–281.
- Nautz, D.: 1995, Optimal bidding in multi-unit auctions with many bidders, *Economics Letters* **48**, 301–306.
- Picinini, A. and Loseby, M.: 2001, *Agricultural policies in Europe and the USA*, 1 edn, Palgrave.
- Ritson, C. and Harvey, D.: 1997, *The Common Agricultural Policy*, 2 edn, CAB International.
- Satterthwaite, M. A. and Williams, S. R.: 1989, The rate of convergence to efficiency in the buyer's bid double auction as the market becomes large, *Review of Economic Studies* **56**, 477–498.
- Satterthwaite, M. A. and Williams, S. R.: 2002, The optimality of a simple market mechanism, *Econometrica* **70**(5), 1841–1863.
- Schotter, A.: 1998, in *Organization With Incomplete Information*, m. majumdar edn, Cambridge University Press, chapter A Practical Person's Guide to Mechanism Selection: Some Lessons From Experimental Economics.

- Vries, S. D. and Vohra, R. V.: 2003, Combinatorial auctions: A survey, *INFORMS Journal on Computing* **15**(3), 284–309.
- Walras, L.: 1874. Translated as: Elements of Pure Economics, by Richard D. Irwin, Homewood, Illinois, 1954.
- Weisstein, E.: 1999, From mathworld - a wolfram web resource,
<http://mathworld.wolfram.com/NP-HardProblem.html>. Access 15 January 2007.
- Wilson, R.: 1985, Incentive efficiency of double auctions, *Econometrica* **53**(5), 1101–1115.
- Wolfers, J. and Zitzewitz, E.: 2004, Prediction markets, *Journal of Economic Perspectives* **18**(2), 107–126.
- Yoon, K.: 2001, The modified vickrey double auction, *Journal of Economic Theory* **101**, 572–584.
- Yoon, K.: 2003, An efficient double auction, *Working paper*, Korea University.